

MULTITEL 220 ALU/AF – NISSAN CABSTAR 120.35

Ente	Rev.	Descrizione	Data	Dis.	Contr.	Ap.A0
MRK	0	EMISSIONE	07-06-00	W.B.		
INGOMBRO - SCHEDA 54/1 - Rev. 0 - 15/12/00						

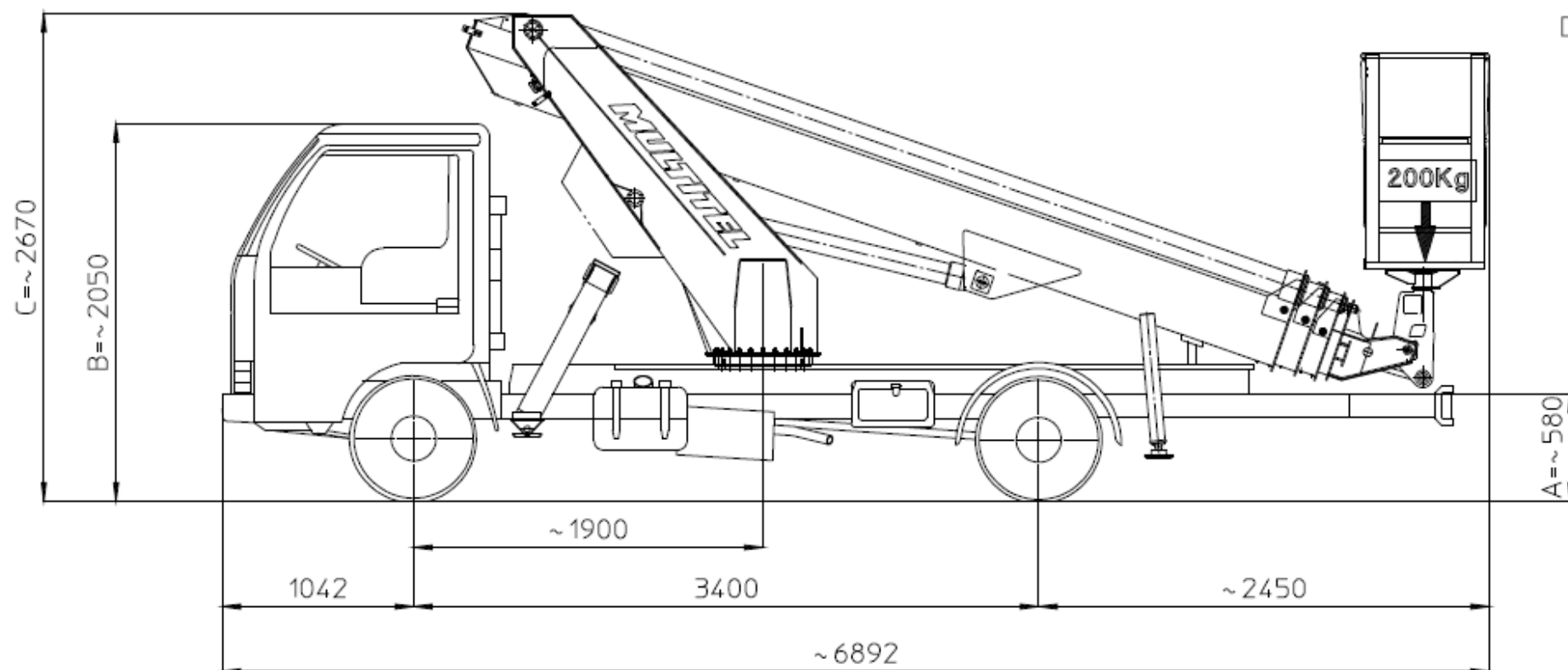

Le quote A-B sono relative alle dimensioni dell'autocarro, quindi devono essere verificate sullo stesso.
La quota C (altezza totale) e' subordinata alle quote A-B.

Les cotes A-B sont relatives aux dimensions du porteur, donc elles doivent être vérifiées sur le porteur même.
La cote C (hauteur totale) est subordonnée aux cotes A-B.

The dimensions A-B are related to the truck sizes, therefore they must be verified.
The dimension C (total height) is subject to A-B.

Die Abmessungen A-B betreffen die Fahrzeugmasse, daher sollen sie geprüft werden.
Die Abmessung C (Gesamthöhe) hängt von A-B Abmessungen ab.

MULTITEL 180-220 ALU/AF - NISSAN CABSTAR 120.35

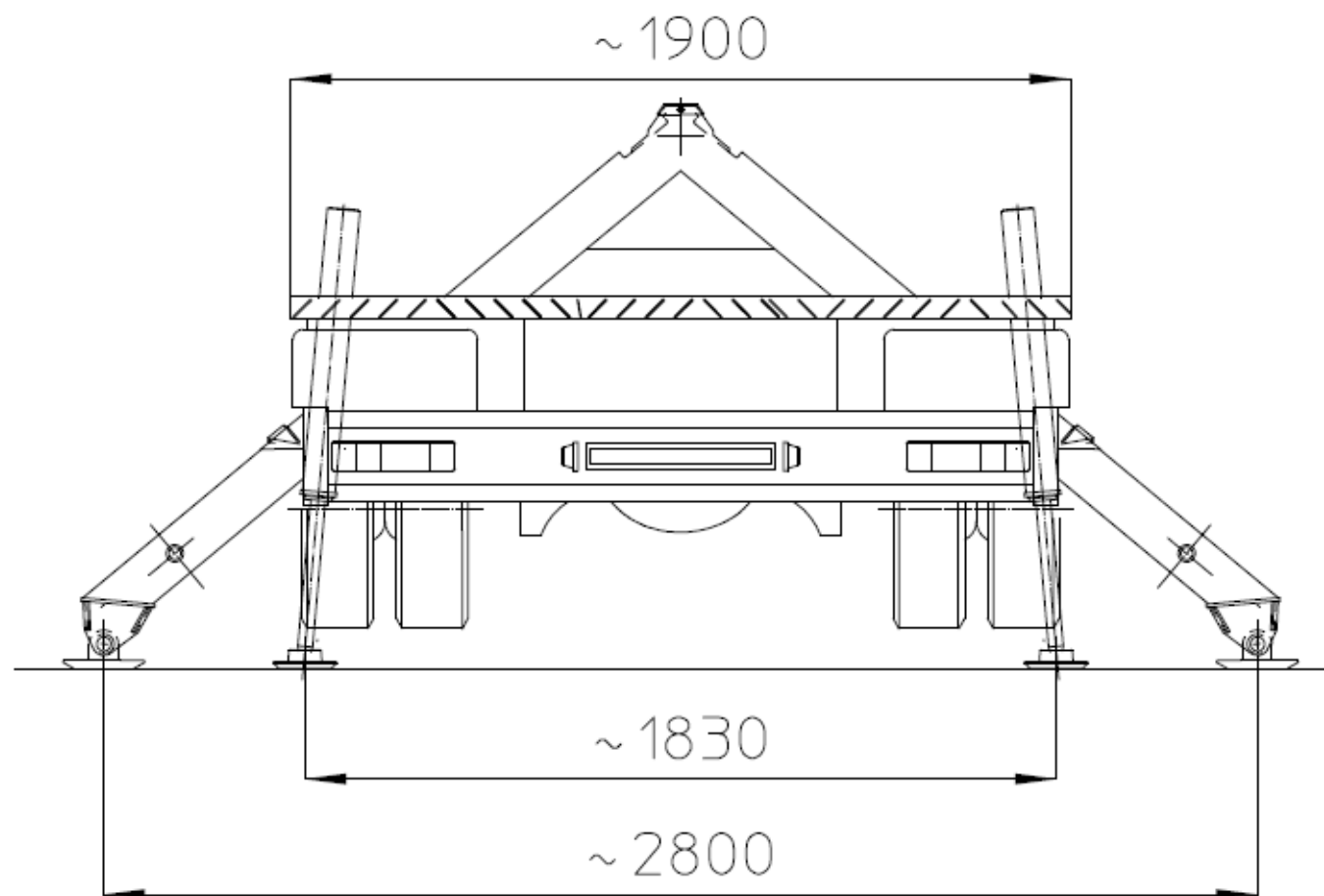

D35679-S1

Ente	Rev.	Descrizione	Data	Dis.	Contr.	Ap.AO
MRK	0	EMISSIONE	08-03-04	W.B.		
INGOMBRO - SCHEDA 54/1 - Rev. 0 - 15/12/00						

MULTITEL 220 ALU

D29306

Ente	Rev.	Descrizione	Data	Dis.	Cont.	AppA0
MRK	0	EMISSIONE	18-04-00	W.B.		

DIAGRAMMA - SCHEDA 54/2 - Rev. 0 - 15/12/00

200Kg **80Kg**

SBRACCIO DI LAVORO	7.8m	10m	±5%
WORKING OUTREACH	7.8m	10m	±5%
DEPORT DE TRAVAIL	7.8m	10m	±5%
SEITLICHE REICHWEITE	7.8m	10m	±5%

